

MICRONTA[®]*

LCD Digital Multimeter



OWNER'S MANUAL

22-191

*TRADEMARKS OF RADIO SHACK DIVISION, TANDY CORPORATION

The MICRONTA LCD Digital Multimeter is a portable 3½-digit, compact-sized Multimeter ideally suited for field, lab, shop, bench and home applications. Here's a review of some of the features that qualify your new Digital Multimeter as a real "pro."

The latest IC and display technology is used to achieve the lowest possible component count. This, in turn, ensures reliability, accuracy, stability and a really rugged, easy-to-handle instrument.

Low battery voltage automatically detected and displayed.

No pointers to bend. No parallax and no mechanical zero-adjust to worry about. Just a high contrast, easy-to-read, 3½-digit, liquid crystal display.

Effective overload and transient protection on all ranges.

Over-range indication on each range.

Full auto-polarity operation.

Dual-slope integration to ensure fast, accurate, noise-free measurements.

Built-in Buzzer function for quick continuity check (sounds when circuit continuity is approximately 300 ohms or less).

Special Diode Check function lets you safely check semiconductor junctions (for open, short or normal).

Switchable electronic Zero-adjust suppresses two least significant digits to assure precise low-range readings.

SPECIFICATIONS

Display	3½-Digit, LCD
Accuracy	
DC VOLTS	±0.8% of reading and
200mV-2-20-200-2000V	±0.2% of full scale,
(Maximum measurement	±1 in last digit
= 1000 Volts)	
AC VOLTS	±1% of reading and
2-20-200-2000V	±0.5% of full scale,
(Maximum measurement	±1 in last digit
= 500 Volts RMS)	at 50/60 Hz

45 to 1 kHz	±1.5% of reading and ±0.5% of full scale, ±1 in last digit	at 20 Volt Range
to 10 kHz	±6% of reading and ±0.5% of full scale, ±1 in last digit	at 20 Volt Range
DC-CURRENT 2–20–200mA	±1.5% of reading and ±0.2% of full scale, ±1 in last digit	
AC-CURRENT 2–20–200mA	±1.5% of reading and ±0.5% of full scale, ±1 in last digit	
RESISTANCE 200Ω–2–20–200–2000KOHM	±1.5% of reading and ±0.2% of full scale, ±1 in last digit +18 digit maximum at 200Ω	
20MΩ	±3.0% of reading and ±0.3% of full scale, ±1 in last digit	
Continuity Function	Continuity buzzer sounds at less than 300 ohm input resistance.	
Diode Check Function	for check if diodes are open or short.	
Input Impedance	10 MEG OHM (DCV/ACV) more than 100 MEG OHM on 200mV DC	
Range Selection	Manual ranging	
Power Source	Two "AA" size 1.5V batteries	
Power Consumption	5mW	
Low Battery Indication	"BATT" on the left of display Below 1.2 – 1.3V	
Polarity	Automatic polarity	
Over-range Indication	1000 with blinking "1"	
Operating Temperature	0°C to 50°C	
Storage Temperature	–20°C to 60°C	
Weight	300g Appro.	
Size	196mm x 90mm x 36mm	
Accessories	Fuse: 0.315A 250V Banana Type Test leads (RS cat. No. 278-704)	

CONTROLS AND FUNCTIONS

ITEM NO.	NAME	FUNCTION
1	Display	A 3½ digit display (1999 max) with decimal point and minus polarity indication. Indicates measured input values and over-range and low battery condition plus 0-ADJ and mV/Ω functions.
2	POWER Switch	Turns the instrument ON and OFF. Set to CONTINUITY for continuity check. Set to ON when Buzzer function is not desired.
3	ZERO ADJUST Switch	Push to suppress the two least significant digits. Push again (or change Range/Function switch position) to cancel 0-ADJ.
4	Input (+) Jack	Connect (+) red lead for all voltage, current and resistance measurements.
5	Input (-) Jack	Connect (-) black lead for all measurements.
6	Function Switch	For selecting functions: DC V, AC V, \rightarrow CHECK, K Ω, DC mA, AC mA
7	Range Switch	For selecting ranges: Voltage: DCV 200mV, 2V, 20V, 200V, 1000V ACV 2V, 20V, 200V, 500V Current: 2mA, 20mA, 200mA Resistance: 200Ω, 2K, 20K, 200K, 2000K, 20MΩ \rightarrow CHECK:
8	Battery/Fuse Compartment	Open to install/replace fuse and/or batteries.

EXPLANATION OF SPECIAL PANEL MARKINGS

Special marking has been added to the panel to remind you of the measurement limitations and safety.

- A. $\frac{500V}{MAX}$  To avoid electrical shock and/or instrument damage do not connect the common input terminal (-jack) to any source of more than 500 volts with respect to earth/ground.

- B. 1000V DC The maximum voltage or current that can be measured is 1000 V DC,
500V AC, or 200mA.
- C. MAX ⚡ Be extra careful when making measurements for high voltage; do not touch terminals or probe ends.
- D. ⚠ Refer to complete operating instructions.

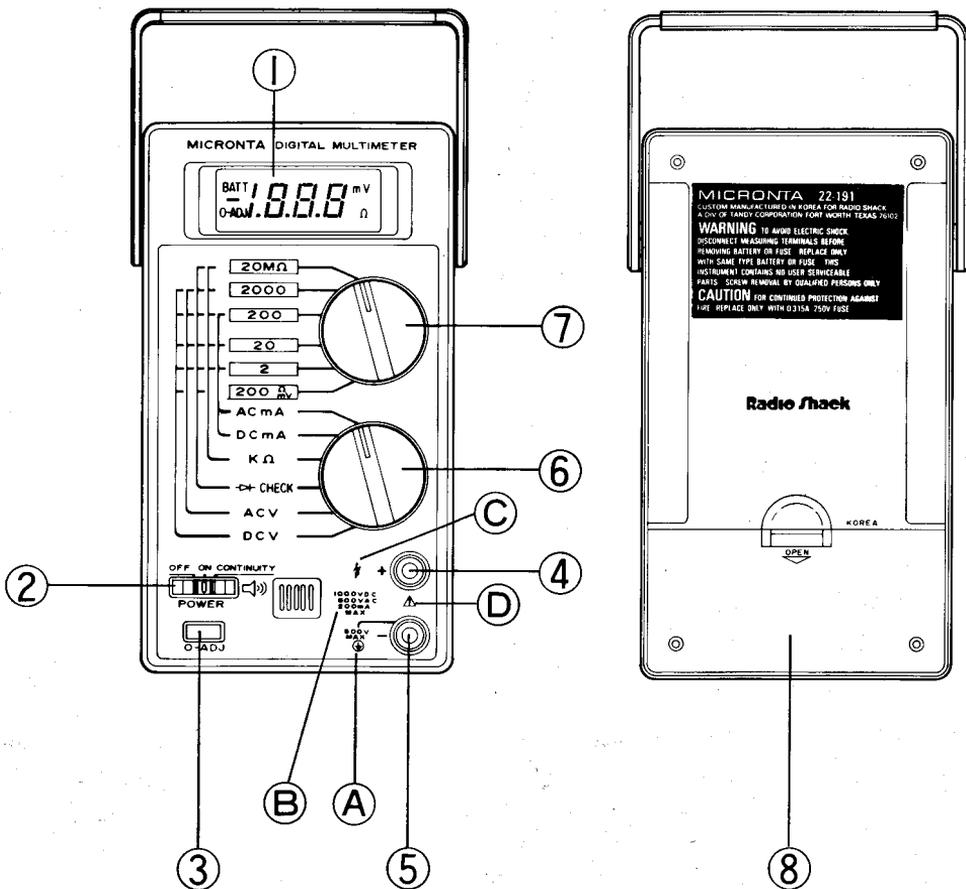

Preparing for Operation

All you need to do is load two 1.5 Volt "AA" batteries. We recommend that you use the Alkaline type — such as Radio Shack's 23-552.

Be sure **POWER** is OFF and test leads are disconnected.

Open the Battery/Fuse Compartment cover on the rear by pressing in the direction of the arrow. Snap the two 1.5 volt batteries in place and press the Battery/Fuse Compartment cover back on.

When the batteries become weak "BATT" will be displayed on the left side of the display. Replace batteries. NEVER LEAVE A WEAK OR DEAD BATTERY IN YOUR UNIT. Even "leak-proof" types can leak and cause damage to the circuitry. When you are not going to use your unit for a few weeks, remove batteries.

Use only the same type of test leads as are supplied with your unit. These test leads are rated for 1000 volts; replacements are available from your local Radio Shack store (Radio Shack Cat. No. 278-704).

Check Before Operation

1. Plug the red test lead into the (+) jack, and the black test lead into the (–) jack.
2. Turn **POWER ON**.
3. Turn the Function Switch to $K \Omega$.
4. With no resistance connected across the test leads, the over-range indication should occur, and display will show "1000" (with blinking "1"). Short the test leads; the display now should be three zeroes.
5. Touch the red probe tip to the black probe tip, and rotate the Range Switch, starting at the top ($20M\Omega$). The decimal point in the display should be positioned as follows:

20 $M\Omega$	0.00
2000 K OHM	000
200 K OHM	00.0
20 K OHM	0.00
2 K OHM	.000
200 Ω	00.0 Ω

MAKING MEASUREMENTS

DC Voltage Measurements/AC Voltage Measurements

IMPORTANT: The maximum input limit for voltage measurements is 1,000V DC and 500V RMS AC. You cannot measure above these limits even with the Range Switch set to "2000". If you attempt to measure DC voltages above 1000 volts or AC voltages above 500 volts RMS, your unit may be damaged.

1. Set Function Switch to DCV or ACV.
2. Set Range Switch as required for the voltage level to be measured. If you don't know the voltage level, start out with the Range Switch set to the highest position and reduce the setting as required to obtain a satisfactory reading.

3. Connect the probes to the circuit to be tested. In DCV, a minus sign will appear if voltage is negative (with respect to black lead).
4. If the voltage exceeds the maximum on the range selected, the display will indicate an over-range "1000" (with blinking "1"). Select a higher range.

NOTE:

When the Function Switch shifts from "KΩ" or " → CHECK" to DC 200mV range, the digital counter displays over indication for a while because the input impedance is too high.

The counter indicates zero by short-circuiting the plus and minus terminals of test leads.

Resistance Measurements

NOTE: The resistance measuring circuit applies a known value of constant current through the unknown resistance and then measures the voltage developed across it. Thus, when checking "in-circuit" resistance, be sure the circuit under test has all power removed (are all capacitors fully discharged?).

1. Set the Function Switch to the K Ω position.
2. Set the Range Switch to the desired position.
3. Connect the probes across the circuit to be measured.
4. If the resistance value being measured exceeds the maximum value of the range selected, an over-range indication will be displayed "1000" (with blinking "1"). Select a higher range. For resistances of approximately 1 Megohm and above, the Meter may take a few seconds to stabilize. This is normal for high resistance readings.

NOTE 1

Your unit has a circuit to protect the resistance ranges from over-voltage. When measuring on the 200Ω range, the resistance of this circuit may affect the reading. To determine the error, short the test leads: the reading is the resistance of the circuit. Subtract this figure from the measured reading. Typically the circuit resistance is 1.8 ohms at its maximum. Or you can use 0-ADJ function (see page 9).

NOTE 2

Some devices may be damaged by the current applied during resistance measurements. The following table lists the voltage and current available on each range.

RANGE	A	B	C
200Ω	1.5V	240mV	1.4mA
2KΩ	0.65V	210mV	160μA
20KΩ	0.65V	315mV	30μA
200KΩ	0.65V	350mV	4μA
2000KΩ	0.65V	360mV	0.4μA
20MΩ	0.65V	360mV	0.04μA

A is open circuit voltage at the jacks in volts.

B is voltage in volts across a resistance equal to full scale value.

C is current in milliamps through a short circuit at the input jacks.

All values are typical.

NOTE 3

If you accidentally connect the resistance function to a power source greater than 80 Volts the fuse will blow (to protect internal circuitry). This may be easily verified by shorting the test leads. If the fuse is open, the reading will be "1000" (with blinking "1") and if not, the reading will be "000."

DIODE CHECK

Since open-circuit voltage between input jacks is maintained at 1.5 Volts (when in the → CHECK function), you can check continuity of most diodes, transistors, etc.

1. Set the Function Switch to the → CHECK position. The range is automatically set to 200Ω .
2. Remove power from the circuit under test.
3. Connect probes to the semi-conductor device you want to check.
4. If the device is good, the display will show some value. If over-range occurs, try reversing polarity: if over-range still occurs, the device is open. If reading is very small or zero, the device is shorted.

NOTE: This multimeter cannot measure forward resistance of LED because this measurement needs more than about 2.1 volts.

DC Current Measurement / AC Current Measurements

To measure current, you must break the circuit and connect the leads to two circuit connection points. **Never connect the leads across a voltage source;** doing so will blow the Tester's fuse or, even worse, may damage the circuit under test.

The maximum input limit for DC current/AC current measurement is 200mA.

1. Place the Function Switch in the DCmA or ACmA position.
2. Set the Range Switch to the desired position. Always set the Range Switch to the highest position if you don't know the amount of current to be measured.
3. **Remove power from the circuit under test** and then break the circuit at the appropriate point.
4. Connect probes to the circuit.
5. Apply power and read current.
6. In DCmA if the polarity of the current being measured is negative, the value displayed will be preceded by a minus (−) sign.
7. If the magnitude of the current being measured exceeds the selected Range, the over-range circuitry will operate, displaying "1000" (with blinking "1"). When this occurs, immediately remove power from the circuit under test and select a higher current range.

NOTE:

The current ranges are fuse-protected. If inoperative, check the fuse.

WARNING

DON'T APPLY VOLTAGE TO INPUT TERMINALS WHILE FUNCTION SWITCH IS IN DCmA OR ACmA POSITION.

ZERO ADJUST FUNCTION

You can suppress the two least significant digits by pressing 0-ADJ. Press 0-ADJ again or change the position of Function or Range Switch to release 0-ADJ Function. You will find this to be convenient when measuring low resistance. As noted previously the internal resistance affects readings on the 200 ohm range. To avoid this, first short the leads; the display will show 1.8 ohms at its maximum. Press 0-ADJ, and the display will be all zeroes. Measure the resistance, and you will get the correct reading.

Buzzer (continuity test)

This tester has a built-in audible continuity function. Select the $K \Omega$ function. The range is automatically set to 20K OHM. Set the Power switch to CONTINUITY position.

Connect probes to the circuit you want to check. If the circuit continuity is 300 ohms or less, the buzzer will sound.

The CONTINUITY position will also result in sounds with function settings other than $K \Omega$ (that is, DCV/ACV/DCmA/ACmA):

1. When function or range switch setting is changed (one short tone).
2. When over-range takes place (two short tones).

NOTE: Buzzer does not sound in the 0-ADJ mode.

Replacement of Battery/Fuse

WARNING: TO AVOID ELECTRIC SHOCK, DISCONNECT MEASURING TERMINALS BEFORE REMOVING BATTERIES OR FUSE. REPLACE ONLY WITH SAME TYPE BATTERIES OR FUSE.

THIS INSTRUMENT CONTAINS NO USER SERVICEABLE PARTS.

SCREW REMOVAL BY QUALIFIED PERSONS ONLY.

CAUTION: FOR CONTINUED PROTECTION AGAINST FIRE, REPLACE ONLY WITH 0.315A, 250V FUSE.

NOTE:

The fuse used in your Digital Multimeter is a special size and type. It can only be ordered from Radio Shack's National Parts Department. Contact your local Radio Shack store to place such a special order.

1. Be sure **POWER** is OFF and test leads are disconnected.
2. Open the Battery/Fuse Compartment Cover.
3. Pull the red ribbon in the Fuse Compartment; the fuse will pop out.
4. Insert a new fuse on the ribbon ring. Use only a fuse of the same type/rating (0.315A, 250V, 5 ϕ x 20mm Miniature fuse).
5. Install fuse with ribbon in the Fuse Compartment.
6. Close the Battery/Fuse Compartment Cover.

WARNING: DO NOT OPERATE YOUR UNIT UNTIL THE BATTERY/FUSE COVER IS IN PLACE AND FULLY CLOSED.

MAINTENANCE

Your Digital Multimeter is a precision electronic device. Do not touch any of the circuitry inside the Case. Do not expose to extreme temperatures [below -4°F (-20°C) or above 140°F (60°C)] ; protect from extremely humid areas.

To avoid damage:

- A. Never connect more than 1000 Volts DC or 500 Volts RMS AC.
- B. Never connect a source of voltage when Function Switch is in $\text{K } \Omega$ position.
- C. Never operate the DMM unless the Battery Cover is in place and fully closed.
- D. Battery and/or Fuse replacement should only be done after the test leads have been disconnected and **POWER** is OFF.

The Micronta DMM comes to you fully calibrated and tested. Under normal use, no further adjustment should be necessary. In case meter should require repair, do NOT try to adjust by yourself; bring it to your nearest Radio Shack store. **SERVICE OF THE DMM BY UNAUTHORIZED PERSONNEL WILL VOID THE WARRANTY.**

A Word About Safety

Every precaution has been taken in the design of your meter to insure that it is as safe as we can make it.

However, **safe operation depends on you**, the operator. We recommend that you follow these simple safety rules:

1. Never apply voltages to the DMM that exceed the limits given in the Specifications section. Never apply more than 1000 Volts DC or 500 Volts RMS AC between input jacks and/or ground.
2. Use extreme caution when working with voltages above 100V. Always disconnect power from the circuit being measured before connecting test leads to high-voltage points.
3. Always discharge filter capacitors before attaching test leads to a power supply.
4. Get into the habit of keeping one hand in your pocket when trouble-shooting any equipment containing high voltages.
5. Since many AC-DC sets have a potentially "hot" chassis, be sure that the top of your workbench and the floor underneath it is dry and is made of non-conductive material.

SCHEMATIC DIAGRAM

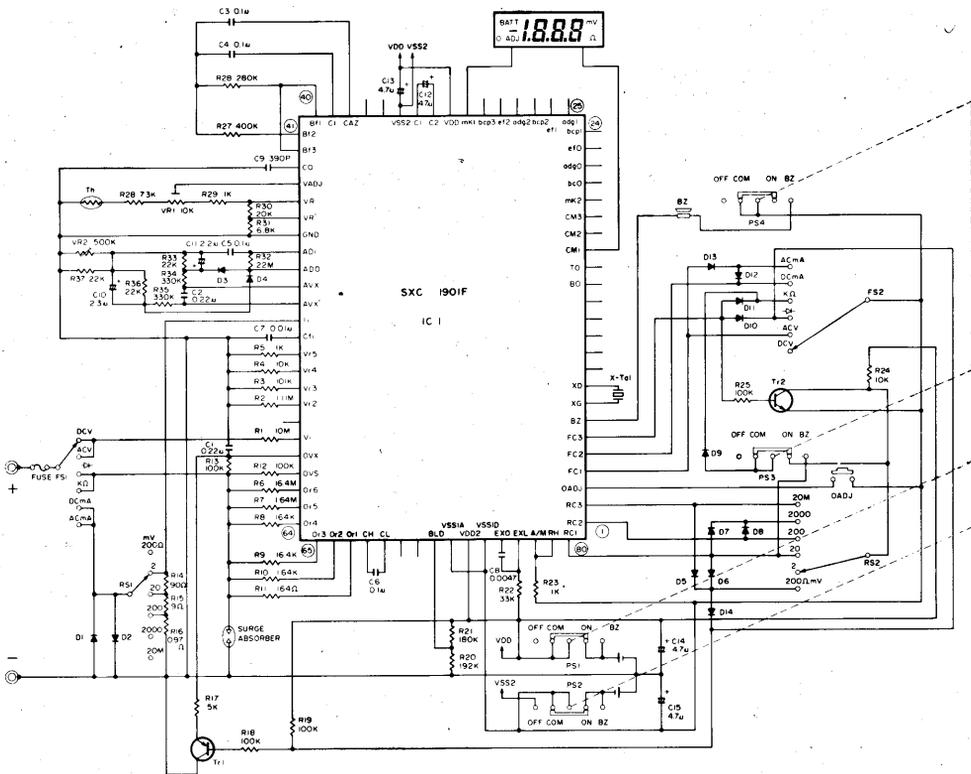

NOTE:

- (1) ALL RESISTANCE VALUES ARE INDICATED IN "OHM" (K = 10^3 OHM, M = 10^6 OHM)
- (2) ALL CAPACITANCE VALUES ARE INDICATED IN "μF" (P = 10^{-6} μF)