

# INNOLUX DISPLAY CORPORATION

## BT156GW01 V.2 LCD MODULE SPECIFICATION

- (●) Preliminary Specification  
( ) Final Specification

Customer	Checked & Approved by
Acer Incorporated	

Approved by	Checked by	Prepared by
MKT	PD	PM
		Annie Lu

Date: 2009/05/18

### **Innolux Display Corporation**

No.160 Kesyue Rd., Chu-Nan Site, Hsinchu Science Park,

Chu-Nan 350, Miao-Li County, Taiwan

Tel: 886-37-586000

Fax: 886-37-586060

Version: 1.2

InnoLux copyright  
All rights reserved,  
Copying forbidden.

## Record of Revision

Version	Revise Date	Page	Content
0.0	2009/03/06	All	First Edition issued
1.0	2009/03/30	2	→Glass Thickness 0.5mm →LED life time with module 12,000 hrs
		6	→Stable rush current value on Specification →BL power consumption @100 nits with full white pattern →Logic power consumption @100 nits with full white pattern →Total power consumption @100 nits with full white pattern
		13	LED Circuit block
		14	→Uniformity 1.25 on avg. of 5 points →Uniformity 1.5 on avg. of 13 points →View Angle at CR ≥ 100: 25 / 25 / 11 / 6 (Right / Left / Bottom / Top)
		22	Write the word "In order to avoid IC damage, it is not allowed to have such overlapping as cables or antennas, camera, WLAN, WWAN over these COF locations" by red color on Specification of 2 D drawing
		23	→COF, T-con, VR location →Module exploding map
1.1	2009/05/07	20	Box Label content update
		24	System Cover Design Notice
		25	EDID code update
1.2	2009/05/18	12	LED PWM frequency 1000Hz (Typ.) Add Note for PWM duty cycle linearity 10%~100%
		14	→Uniformity 1.25 on avg. of 5 points (Max.) →Uniformity 1.5 on avg. of 13 points (Max.)

<b>Contents:</b>	<b>Page</b>
<b>1. General Specifications</b>	<b>2</b>
<b>2. Electrical Specifications</b>	
<b>2-1 Pin Assignment</b>	<b>3</b>
<b>2-2 Absolute Maximum Ratings</b>	<b>5</b>
<b>2-3 Electrical Characteristics</b>	<b>6</b>
<b>3. Optical Specifications</b>	<b>14</b>
<b>4. Reliability Test Items</b>	<b>17</b>
<b>5. Safety</b>	<b>18</b>
<b>6. Display Quality</b>	<b>18</b>
<b>7. Handling Precaution</b>	<b>18</b>
<b>8. Label Definition</b>	<b>19</b>
<b>9. Packing Form</b>	<b>21</b>
<b>10. Mechanical Drawings</b>	<b>22</b>
<b>11. System Cover Design Notice</b>	<b>24</b>
<b>Appendix</b>	<b>25</b>

**1. General Specifications**

<b>NO.</b>	<b>Item</b>	<b>Specification</b>	<b>Unit</b>
1	Display resolution (pixel)	1366(H) X 768(V), HD resolution	
2	Active area	344.232(H) X 193.536(V)	mm
3	Screen size	15.6 inches diagonal	Inches
4	Pixel pitch	0.252(H) X 0.252(V)	mm
5	Color configuration	Stripe	
6	Overall dimension	359.8(W) X 210(H) X 5.5(D) (max)	mm
7	Weight	450 Max.	Grams
8	Surface treatment	Glare, 3H	
9	Input color signal	6 bit LVDS	
10	Display colors	262K (6 bit)	
11	Optimum viewing direction	6 o'clock	
12	Backlight	W-LED	
13	Glass thickness	0.5	mm
14	LED life time with module	12,000 (min.), T = 25°C	Hours
15	RoHS	RoHS compliance	

## 2. Electrical Specifications

### 2-1 Pin Assignment

#### a. Panel connector

Connector Part No.: 20455-040-12 (I-PEX) or equivalent

User's connector Part No: 20453-040T-12 (I-PEX) or equivalent

Pin No	Symbol	Description	Remark
1	NC	No connection (Reserve)	
2	V <sub>CC</sub>	Power Supply (+3.3V)	
3	V <sub>CC</sub>	Power Supply (+3.3V)	
4	V <sub>EDID</sub>	DDC Power +3.3V	
5	NC	No connection (Reserve)	
6	CLK <sub>EDID</sub>	DDC Clock	
7	DATA <sub>EDID</sub>	DDC Data	
8	Rxin0-	Differential Data Input	R0~R5,G0
9	Rxin0+	Differential Data Input	
10	GND	Ground	
11	Rxin1-	Differential Data Input	G1~G5,B0,B1
12	Rxin1+	Differential Data Input	
13	GND	Ground	
14	Rxin2-	Differential Data Input	B2~B5,DE,Hsync,Vsync
15	Rxin2+	Differential Data Input	
16	GND	Ground	
17	CLK-	Differential Clock Input	
18	CLK+	Differential Clock Input	
19	GND	Ground	
20	NC	No connection (Reserve)	
21	NC	No connection (Reserve)	
22	GND	Ground	
23	NC	No connection (Reserve)	
24	NC	No connection (Reserve)	
25	GND	Ground	
26	NC	No connection (Reserve)	
27	NC	No connection (Reserve)	
28	GND	Ground	
29	NC	No connection (Reserve)	
30	NC	No connection (Reserve)	
31	LED_GND	LED Ground	
32	LED_GND	LED Ground	
33	LED_GND	LED Ground	
34	NC	No connection (Reserve)	
35	LED_PWM	PWM dimming signal input	
36	LED_EN	LED enable pin (3.3V)	
37	NC	No connection (Reserve)	
38	V_LED	LED power supply 7.5V~21V	
39	V_LED	LED power supply 7.5V~21V	
40	V_LED	LED power supply 7.5V~21V	

b. General Block Diagram

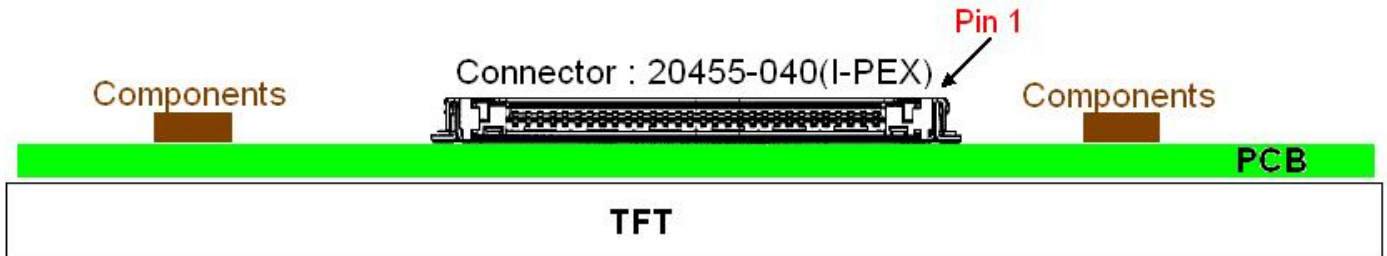
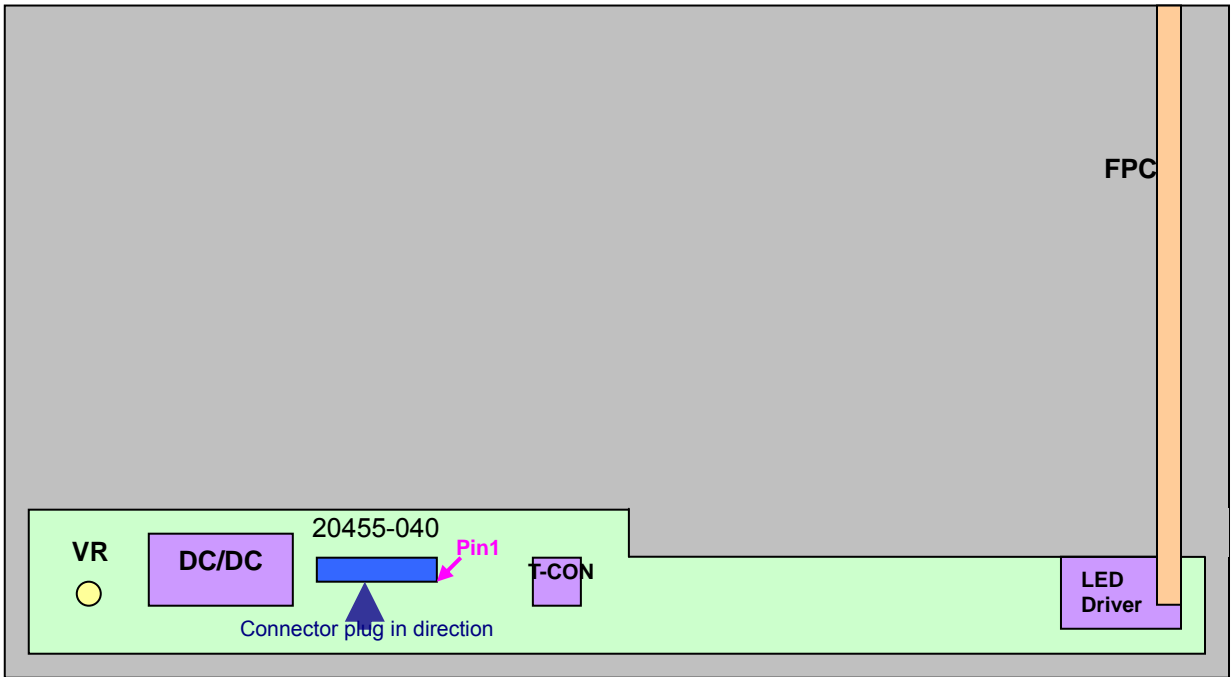

**2-2. Absolute Maximum Ratings**

Parameter	Symbol	Values		Unit	Remark
		Min.	Max.		
Power input voltage	V <sub>CC</sub>	- 0.3	4.0	V	At 25°C
Signal input voltage	V <sub>IN</sub>	- 0.3	4.0	V	At 25°C
LED input voltage	V <sub>LED</sub>	- 0.3	30	V	At 25°C
Operating temperature	T <sub>OP</sub>	0	50	°C	Note 1
Storage temperature	T <sub>ST</sub>	- 20	60	°C	Note 2
Re-screw		-	5	Times	
Assured torque at side mount		-	2	kgf.cm	

Note 1: The relative humidity must not exceed 90% non-condensing at temperatures of 40°C or less. At temperatures greater than 40°C, the wet bulb temperature must not exceed 39°C.

Note 2: The unit should not be exposed to corrosive chemicals.

**Relative Humidity (%RH)**

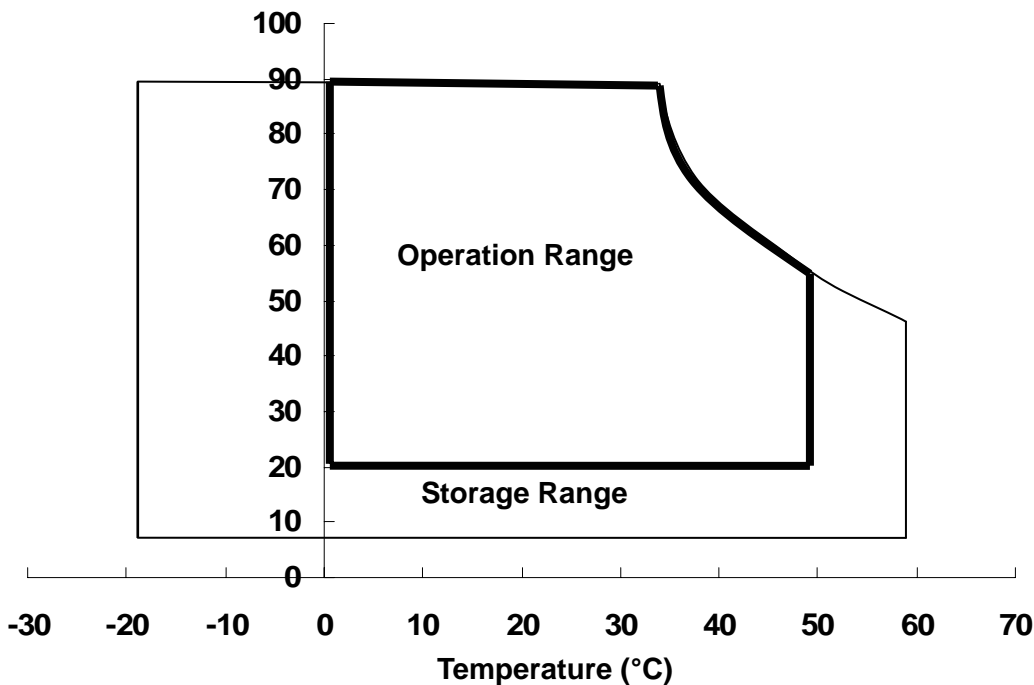

**2-3. Electrical Characteristics**

## a. Typical operating conditions

Item	Symbol	Min.	Typ.	Max.	Unit	Remark	
Power input voltage	$V_{CC}$	3	3.3	3.6	V		
Permissive power input ripple	$V_{RF}$	-	-	0.1	V		
Power input current	$I_{CC}$	-	360	400	mA	Note 1	
Power consumption	$P_{logic}$	-	1.2	1.3	Watts	Note 1	
	$P_{logic-g}$	-	0.8	0.9	Watts	Note 2	
	$P_{total}$		5.1	5.5	Watts	Note 1	
	$P_{total-g}$		3.3	3.6	Watts	Note 3	
LVDS interface	Differential input high threshold voltage	$V_{LVTH}$	-	-	+100	mV	$V_{LVC}=1.2V$ , Note 4
	Differential input low threshold voltage	$V_{LVTL}$	-100	-	-	mV	$V_{LVC}=1.2V$ , Note 4
	Common input voltage	$V_{LVC}$	0.1	1.2	1.4	V	Note 4
	Terminating resistor	$R_T$	90	100	110	ohm	
Initial inrush current	$I_{inrush}$	-	-	1.5	A	Note 5	
Stable rush current	$I_{st-rush}$	-	-	0.0025	$A^2sec$		
LED Initial inrush current	$I_{LED-inrush}$	-	-	3.0	A	Note 6	
LED stable rush current	$I_{LED-st-inrush}$	-	-	0.0075	$A^2sec$		

Note 1: The specified input current and power consumption are under the  $V_{CC} = 3.3V$ ,  $25^\circ C$ ,  $f_V = 60Hz$  (frame frequency) condition whereas black pattern is displayed.

Note 2: The logic power consumption @100 nits with full white pattern under the  $V_{CC} = 3.3V$ ,  $25^\circ C$ ,  $f_V = 60Hz$  (frame frequency) condition

Note 3: The logic power consumption & BL power consumption @100 nits with full white pattern under the  $V_{CC} = 3.3V$ ,  $25^\circ C$ ,  $f_V = 60Hz$  (frame frequency) condition



Note 4: LVDS waveform diagram

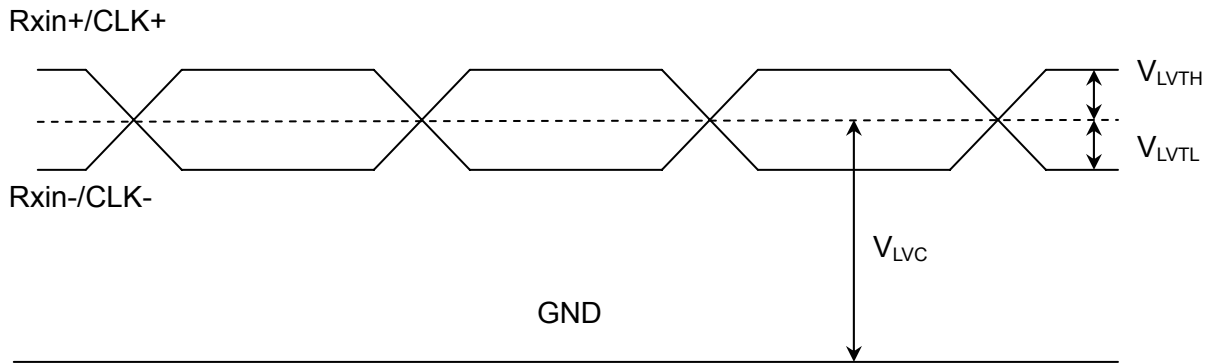

Note 5: Test condition

- (1) Pattern: Black pattern
- (2)  $V_{CC} = 3.3\text{ V}$ ,  $V_{CC}$  rising time =  $470\ \mu\text{s} \pm 10\%$

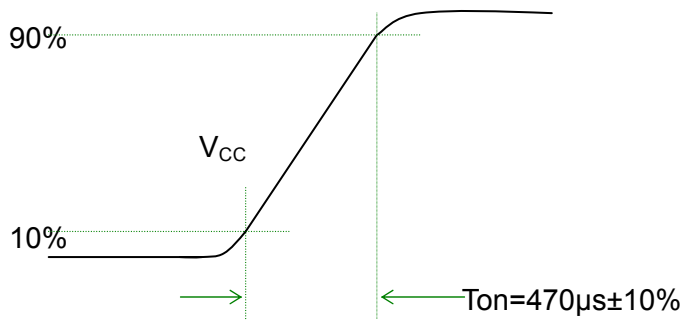

(3) Test circuit

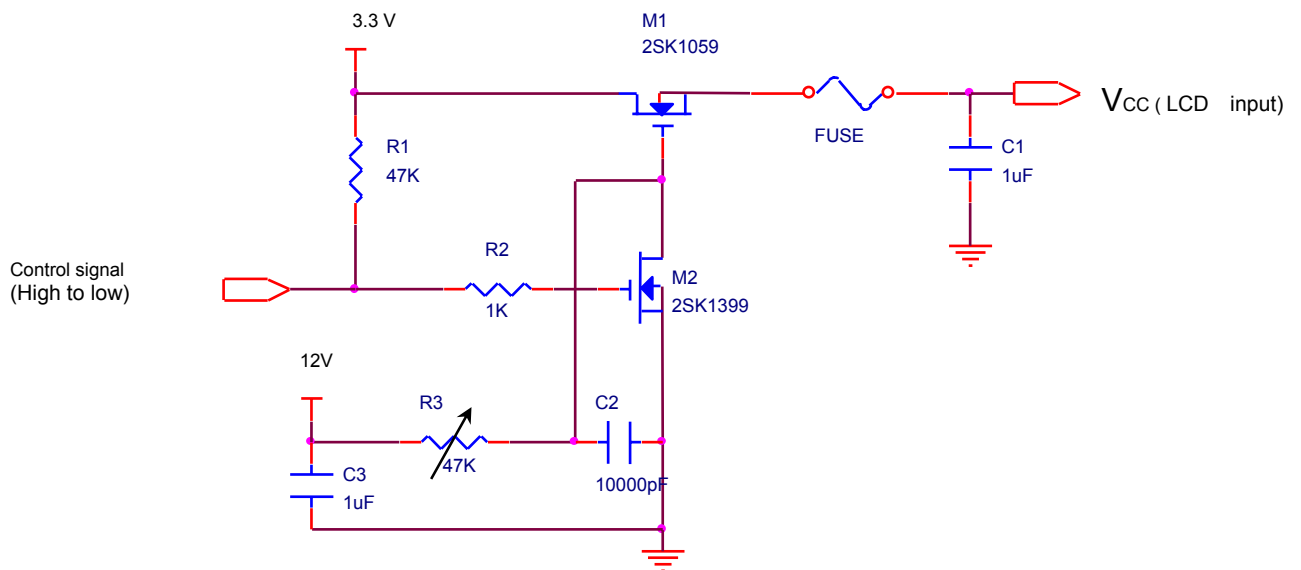

Note 6: Test condition

- (1) Pattern: LED duty 100%
- (2)  $V_{LED} = 12.0V$ ,  $V_{LED}$  rising time =  $470 \mu s \pm 10\%$

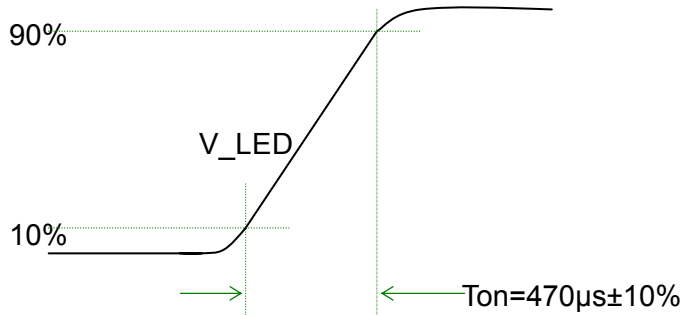

(3) Test circuit

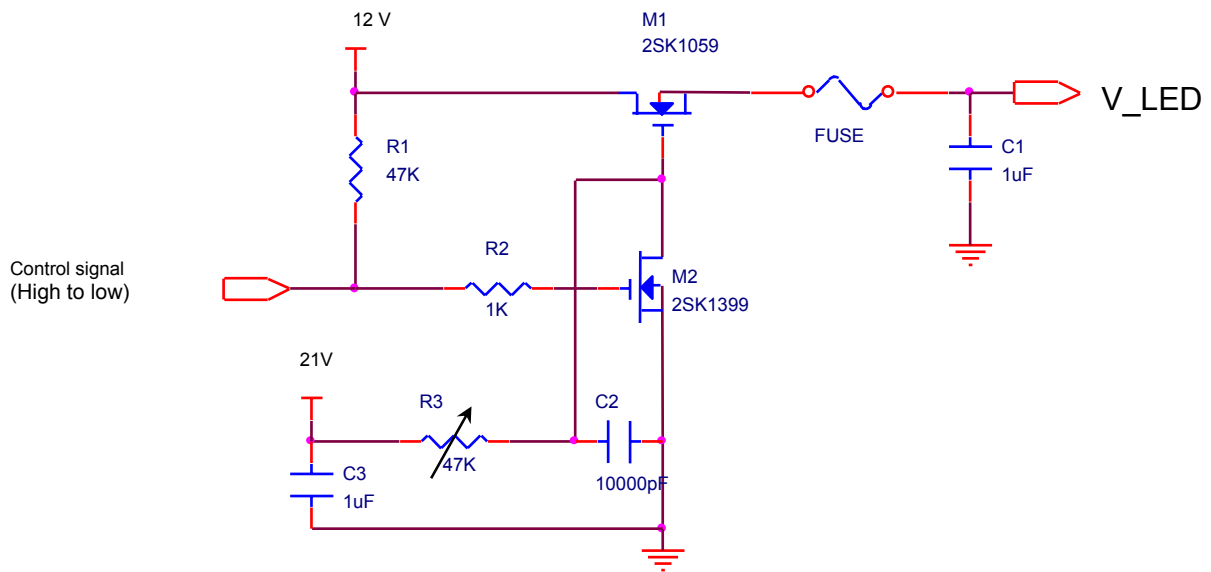

b. Power sequence

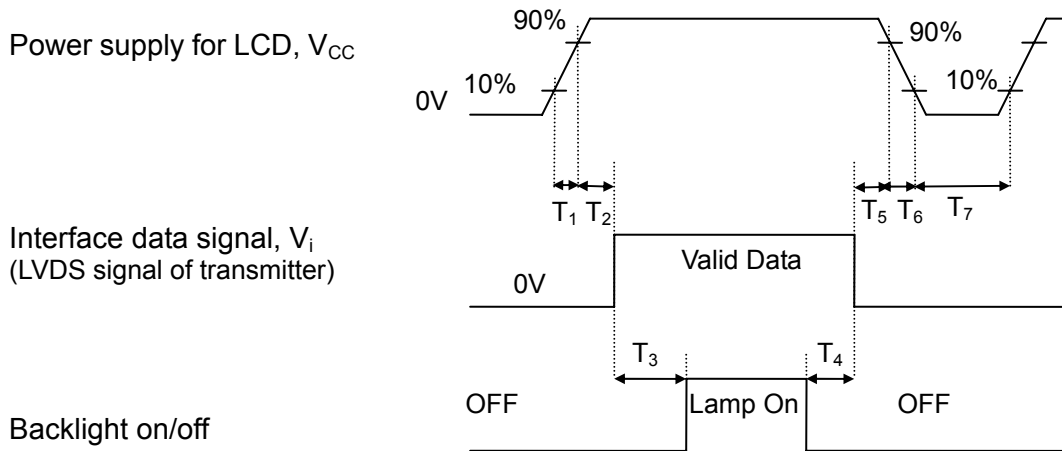

Power sequence timing table

Parameter	Value			Units
	Min.	Typ.	Max.	
$T_1$	0.5	-	10	ms
$T_2$	0	-	50	ms
$T_3$	200	-	-	ms
$T_4$	200	-	-	ms
$T_5$	0	-	50	ms
$T_6$	0	-	10	ms
$T_7$	400	-	-	ms

c. Display color vs. input data signals

Signal Name	Description	Remark
R5	Red Data 5 (MSB)	Red-pixel data. Each red pixel's brightness data consists of these 6 bits pixel data.
R4	Red Data 4	
R3	Red Data 3	
R2	Red Data 2	
R1	Red Data 1	
R0	Red Data 0 (LSB)	
	<b>Red-pixel Data</b>	
G5	Green Data 5 (MSB)	Green-pixel data. Each green pixel's brightness data consists of these 6 bits pixel data.
G4	Green Data 4	
G3	Green Data 3	
G2	Green Data 2	
G1	Green Data 1	
G0	Green Data 0 (LSB)	
	<b>Green-pixel Data</b>	
B5	Blue Data 5 (MSB)	Blue-pixel data. Each blue pixel's brightness data consists of these 6 bits pixel data.
B4	Blue Data 4	
B3	Blue Data 3	
B2	Blue Data 2	
B1	Blue Data 1	
B0	Blue Data 0 (LSB)	
	<b>Blue-pixel Data</b>	

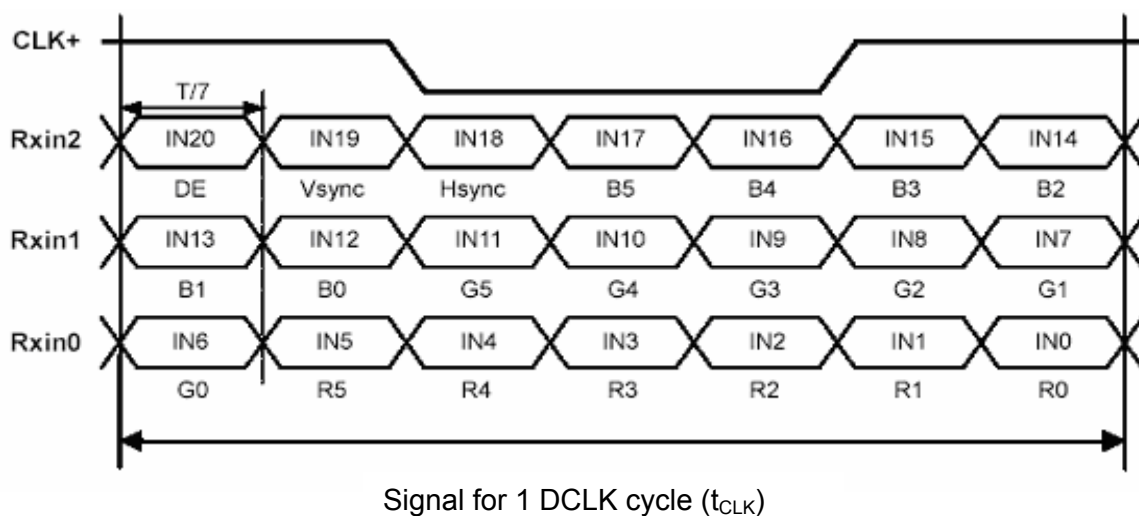

d. Input signal timing

Timing table

Description	Symbol	Min	Typ	Max	Unit
Frame rate	--	50	60	--	Hz
Clock freq.	$1/t_{CLK}$	65	75	85	MHz
Line cycle time	$t_H$	1400	1560	1800	$t_{CLK}$
Line width-active	$t_{Hd}$	1366	1366	1366	$t_{CLK}$
Frame cycle time	$t_V$	780	806	900	$t_H$
V width-active	$t_{Vd}$	768	768	768	$t_H$

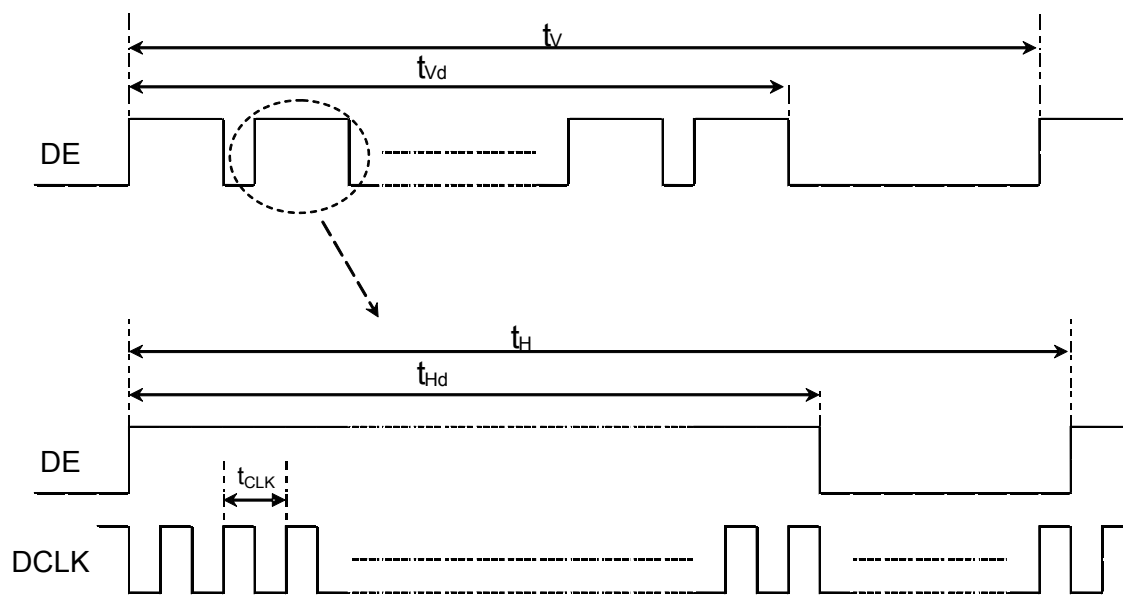

e. Display position

D(1, 1)	D(2, 1)	.....	D(683, 1)	.....	D(1365, 1)	D(1366, 1)
D(1, 2)	D(2, 2)	.....	D(683, 2)	.....	D(1365, 2)	D(1366, 2)
⋮		.....	⋮	.....	⋮	⋮
D(1, 384)	D(2, 384)	.....	D(683, 384)	.....	D(1365, 384)	D(1366, 384)
⋮		.....	⋮	.....	⋮	⋮
D(1, 767)	D(2, 767)	.....	D(683, 767)	.....	D(1365, 767)	D(1366, 767)
D(1, 768)	D(2, 768)	.....	D(683, 768)	.....	D(1365, 768)	D(1366, 768)

f. Backlight driving conditions

Parameter	Symbol	Min.	Typ.	Max.	Unit	Remark
LED Forward Voltage	$V_F$	3	3.2	3.4	$V_{rms}$	$T = 25^{\circ}C$
LED Forward Current	$I_F$		20		$mA_{rms}$	$T = 25^{\circ}C$
LED Power consumption	$P_{LED}$		3.93	4.20	W	$T = 25^{\circ}C$
	$P_{LED-G}$		2.50	2.70	W	Note 1
Input PWM frequency	$F_{PWM}$	200	1000	2000	Hz	$T = 25^{\circ}C$
Duty ratio	-	5		100	%	Note 2
LED life time	-	15,000			Hr	$T = 25^{\circ}C$ , Note 3

Note 1: The BL power consumption @100 nits with full white pattern under the  $V_{cc} = 3.3V$ ,  $25^{\circ}C$ ,  $f_v = 60Hz$  (frame frequency) condition

Note 2: PWM duty cycle linearity guarantees 10~100%.

Note 3: LED life time definition is brightness decrease to 50% of initial or abnormal lighting.

g. Module function block

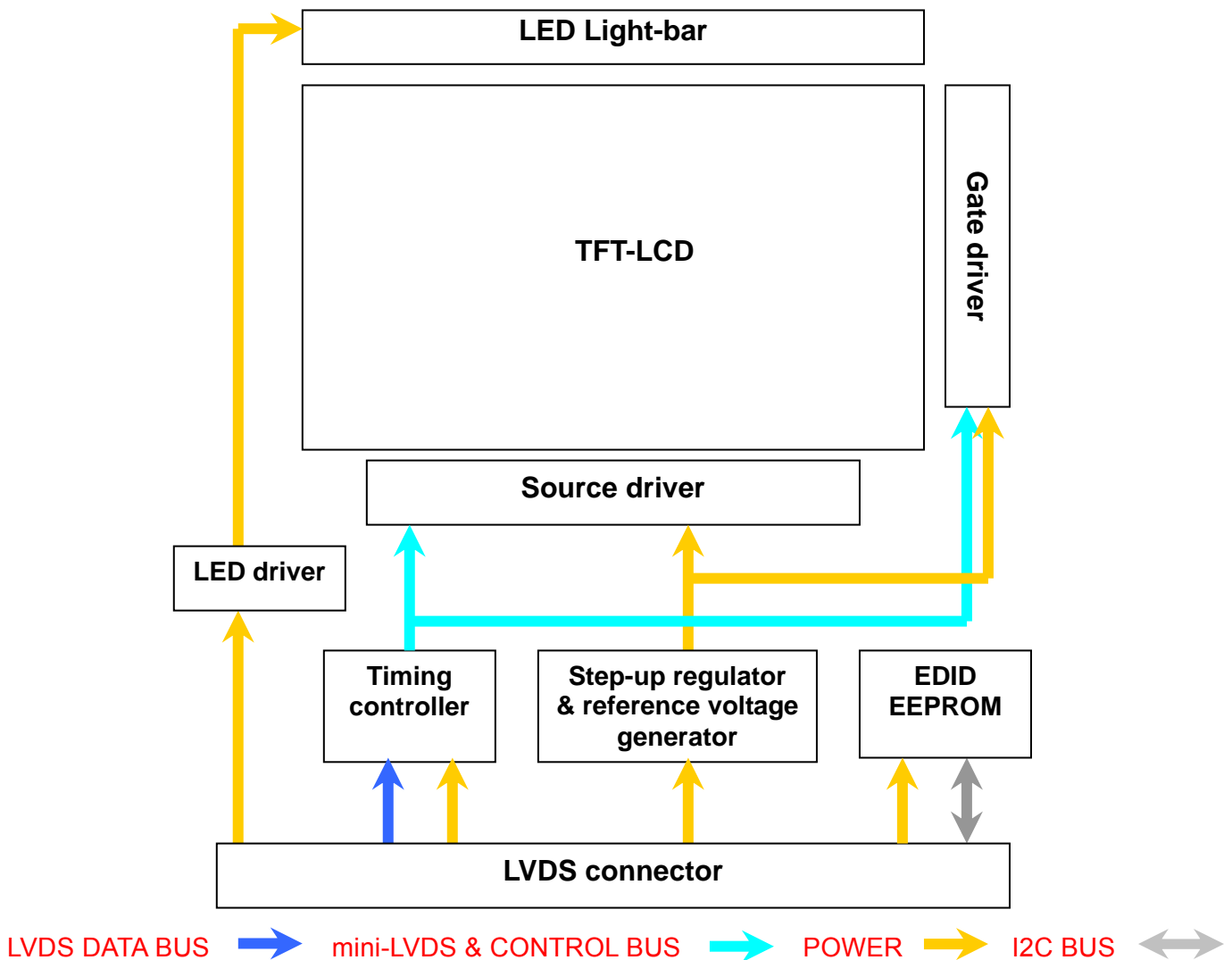

h. LED circuit block

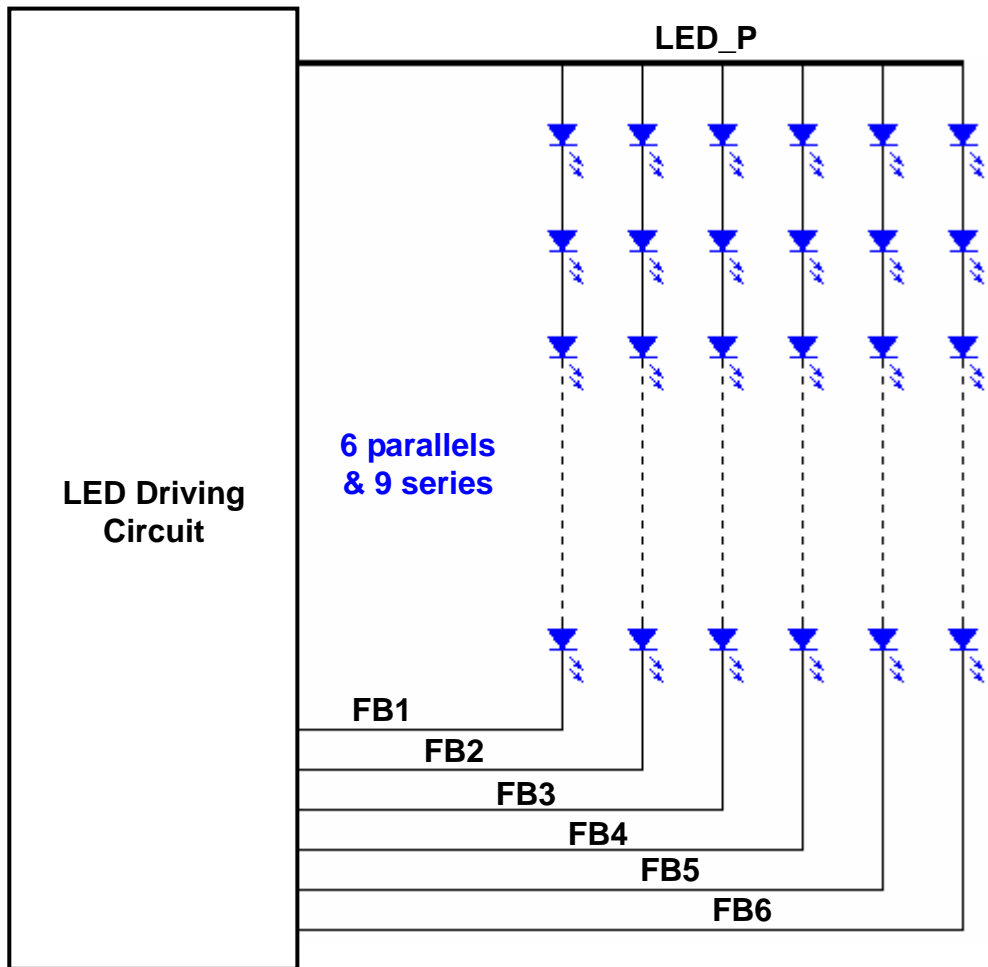

**3. Optical specifications**

Ambient temperature = 25°C

Item	Symbol	Condition	Specification			Unit	Remark
			Min.	Typ.	Max.		
Response time	Tr+Tf	$\theta = 0^\circ$		8	15	ms	Note 3
Contrast ratio	CR	$\theta = 0^\circ$	500	600			Note 2,4
Viewing angle	Top	$CR \geq 10$	15			deg	Note 2,4,6
	Bottom		30				
	Left		40				
	Right		40				
	Top	$CR \geq 100$	6				
	Bottom		11				
	Left		25				
	Right		25				
Brightness (5 points average)	$Y_L$		200	220		nit	Note 2,5
Color chromaticity (CIE)	$W_x$	$\theta = 0^\circ$	-0.03	0.313	+0.03		Note 2
	$W_y$			0.329			
	$R_x$			0.620			
	$R_y$			0.340			
	$G_x$			0.330			
	$G_y$			0.605			
	$B_x$			0.150			
	$B_y$			0.070			
Color gamut	NTSC	CIE1931	56	60		%	-
White uniformity	$\bar{\delta}_{W(5)}$				1.25		Note 2,7
	$\bar{\delta}_{W(13)}$				1.5		
Cross talk	Ct				2%		Note 8



Note 1: To be measured in dark room.

Note 2: To be measured with a viewing cone of 2° by Topcon luminance meter BM-5A.

Note 3: Definition of response time:

The output signals of BM-7 are measured when the input signals are changed from "Black" to "White" (falling time) and from "White" to "Black" (rising time), respectively. The response time interval is between 10% and 90% of amplitudes. Refer to figure as below.

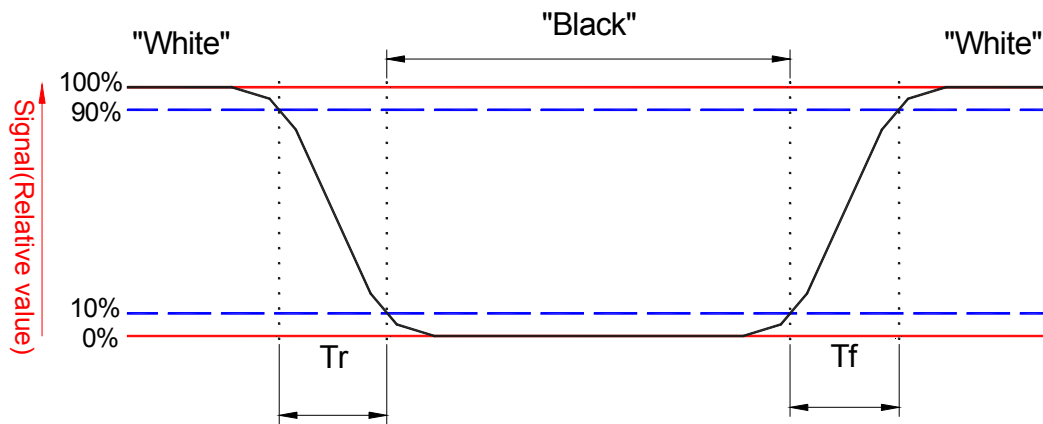

Note 4: Definition of contrast ratio:

Contrast ratio is calculated with the following formula:

$$\text{Contrast ratio (Avg of 5pts)} = \frac{L_{\text{white (Avg of 5pts.)}}}{L_{\text{Black (Avg of 5pts.)}}}$$

Note 5: Driving current for LED should be 20 mA.

Luminance is measured at the following thirteen points (1~13):

$$Y_L = (Y3 + Y5 + Y7 + Y11 + Y12) / 5$$

Note 6: Definition of viewing angle

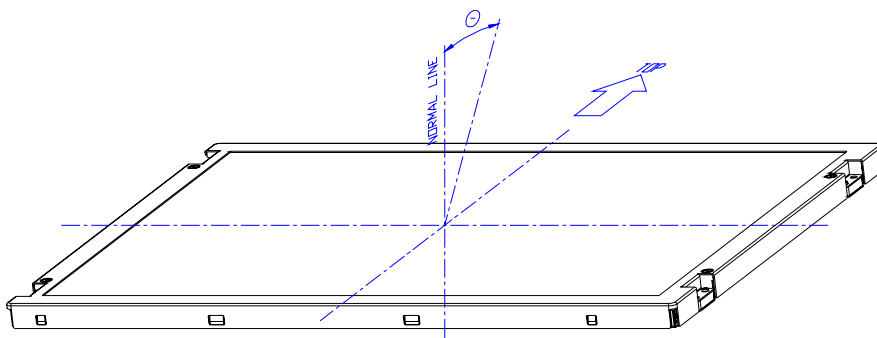

Note 7: Definition white uniformity

Luminance is measured at the following thirteen points (1~13):

$$\delta_{W(13)} = \frac{\text{Maximum brightness of thirteen points}}{\text{Minimum brightness of thirteen points}}$$

$$\delta_{W(5)} = \frac{\text{Maximum brightness of five points}}{\text{Minimum brightness of five points}}$$

13 point measuring locations refer to the point 1, 2, 3, 4, 5, 6, 7, 8, 9, 10, 11, 12 and 13.

5 point measuring locations refer to the point 5, 10, 11, 12 and 13.

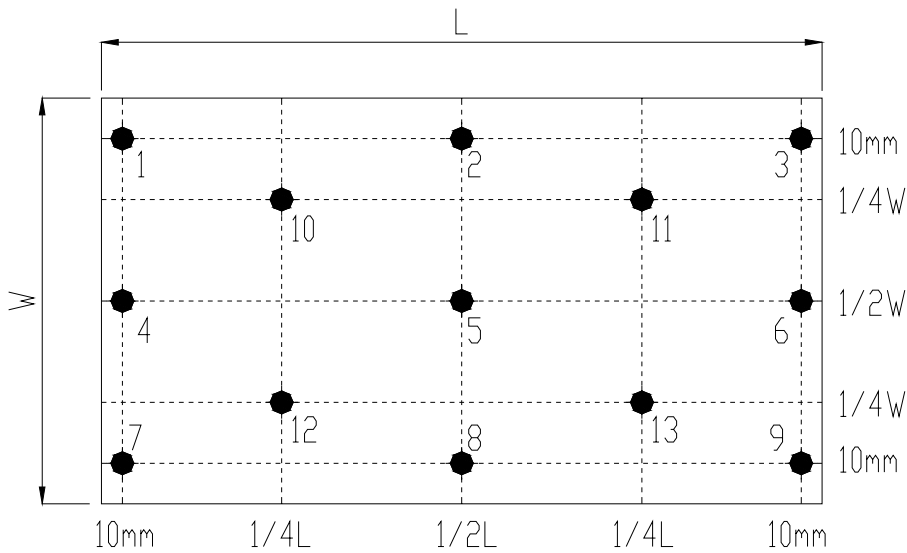

Note 8:

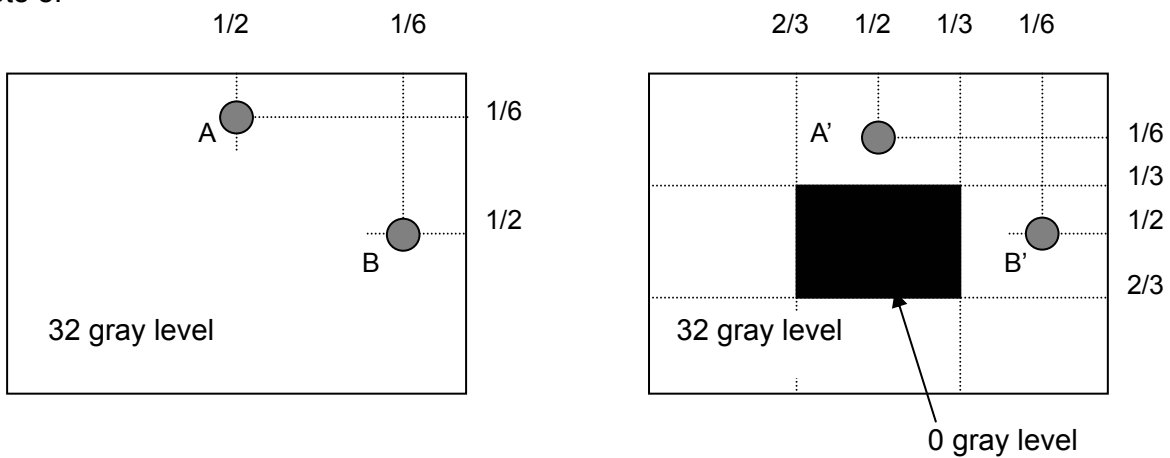

Unit: percentage of dimension of display area

$|L_A - L_{A'}| / L_A \times 100\% = 2\% \text{ max.}$ ,  $L_A$  and  $L_{A'}$  are brightness at location A and A'

$|L_B - L_{B'}| / L_B \times 100\% = 2\% \text{ max.}$ ,  $L_B$  and  $L_{B'}$  are brightness at location B and B'

**4. Reliability test items**

Test Item	Test Condition	Judgment	Remark
High temperature storage	60°C, 240 hours	Note 1	Note 2
Low temperature storage	-20°C, 240 hours	Note 1	Note 2
High temperature & high humidity operation	40°C, 90% RH, 240 hours (No condensation)	Note 1	Note 2
High temperature operation	50°C, 240 hours	Note 1	Note 2
Low temperature operation	0°C, 240 hours	Note 1	Note 2
Thermal Shock (Non-operation)	-25°C / 30 mins ~ 65°C / 30 mins 100 cycles	Note 1	Note 2
Electrostatic discharge (ESD)	150 pF, 330Ω, Contact: ±8kV, Air: ±15kV	Note 1	
Vibration (Non-operation)	1.5G, 10 to 500 Hz random; 0.5hr in each perpendicular axes ( X, Y, Z ).	Note 1	Note 2
Mechanical shock (Non-operation)	220G/2ms, Half sine wave, ±X, ±Y, ±Z one time for each direction	Note 1	Note 2

Note 1: Pass: Normal display image with no obvious non-uniformity and no line defect.

Fail: No display image, obvious non-uniformity, or line defects.

Partial transformation of the module parts should be ignored.

Note 2: Evaluation should be tested after storage at room temperature more than one hour.

## 5. Safety

### 5-1. Sharp edge requirements

There will be no sharp edges or corners on the display assembly that could cause injury.

### 5-2. Materials

#### a. Toxicity

There will be no carcinogenic materials used anywhere in the display module. If toxic materials are used, they will be reviewed and approved by the responsible InnoLux Toxicologist.

#### b. Flammability

All components including electrical components that do not meet the flammability grade UL94-V0 in the module will complete the flammability rating exception approval process. The printed circuit board will be made from material rated 94-V0 or better. The actual UL flammability rating will be printed on the printed circuit board.

#### c. Capacitors

If any polarized capacitors are used in the display assembly, provisions will be made to keep them from being inserted backwards.

## 6. Display quality

The display quality of the color TFT-LCD module should be in compliance with the InnoLux incoming inspection standard.

## 7. Handling precaution

- (1) Do not apply rough force such as bending or twisting to the module during assembly.
- (2) To assemble or install module into user's system can be only in clean working areas. The dust and oil may cause electrical short or worsen the polarizer.
- (3) It's not permitted to have pressure or impulse on the module because the LCD panel and backlight will be damaged.
- (4) Always follow the correct power sequence when LCD module is connecting and operating.
- (5) Do not pull the I/F connector in or out while the module is operating.
- (6) Do not disassemble the module.
- (7) Use a soft dry cloth without chemicals for cleaning, because the surface of polarizer is very soft and easily scratched.
- (8) It is dangerous that moisture come into or contacted the LCD module, because moisture may damage LCD module when it is operating.
- (9) High temperature or humidity may reduce the performance of module. Please store LCD module within the specified storage conditions.

## 8. Label Definition

### 8-1. Module label

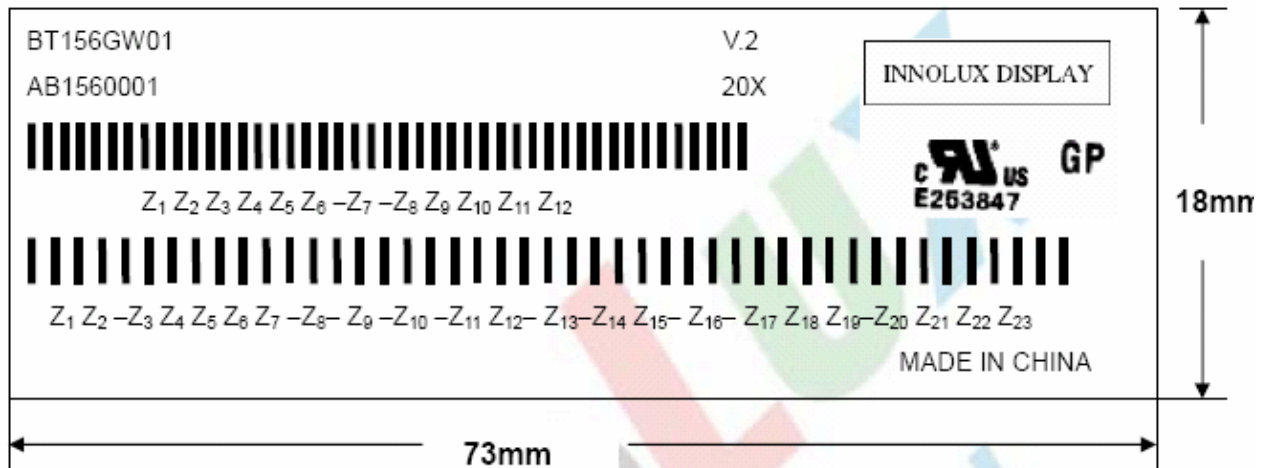

- (1) Model Number : BT156GW01
- (2) Version : V.2
- (3) Product Number : AB156000120X
- (4) Serial ID I (INL Internal Use): Z<sub>1</sub>Z<sub>2</sub>Z<sub>3</sub>Z<sub>4</sub>Z<sub>5</sub>Z<sub>6</sub>-Z<sub>7</sub>-Z<sub>8</sub>Z<sub>9</sub>Z<sub>10</sub>Z<sub>11</sub>Z<sub>12</sub>

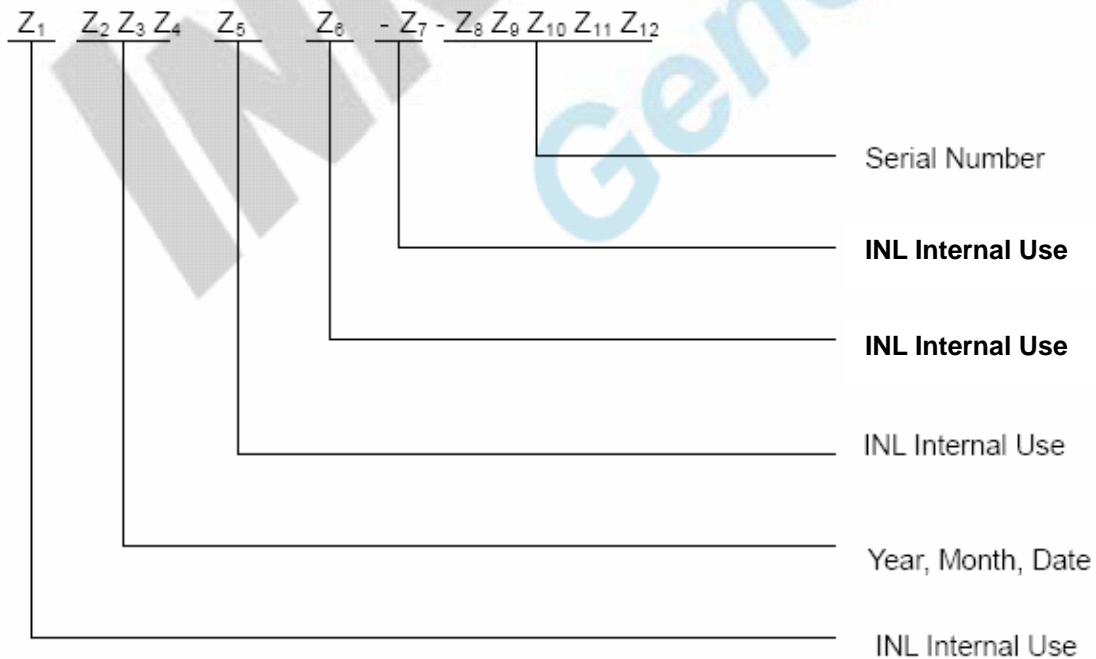

8-2. Carton label

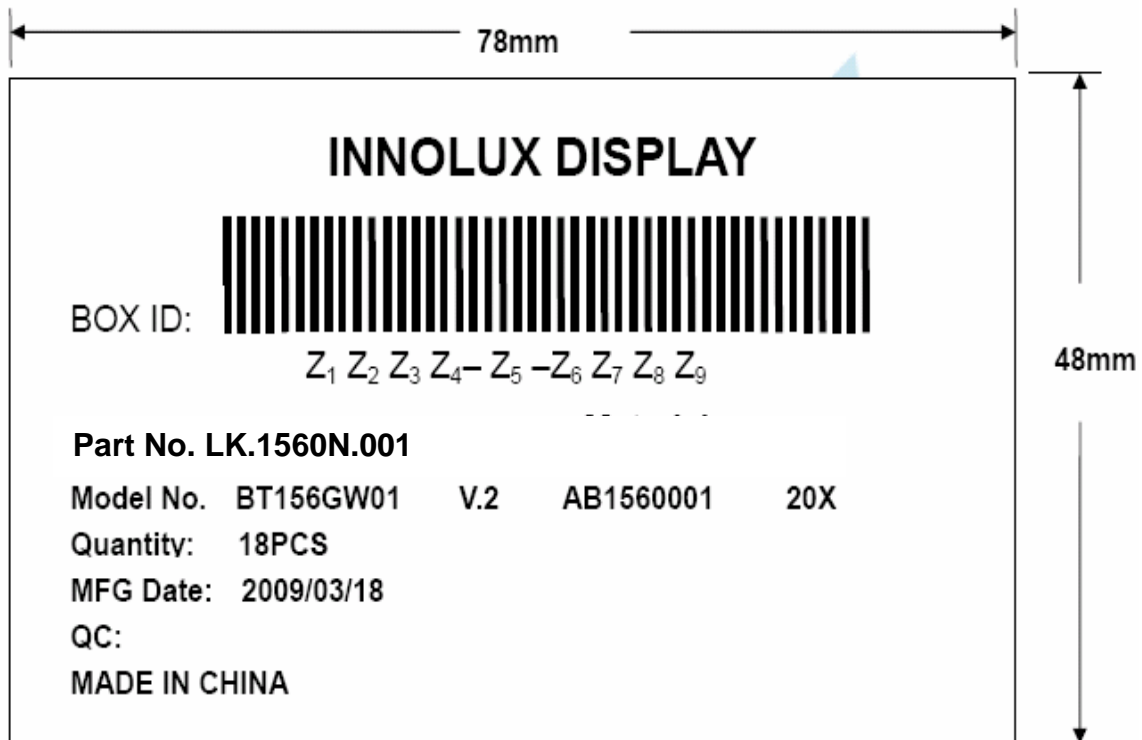

- (1) Model No. :BT156GW01
- (2) Version :V.2
- (3) Package Quantity :18PCS
- (4) Serial ID :

Z<sub>1</sub> Z<sub>2</sub> Z<sub>3</sub> Z<sub>4</sub>-Z<sub>5</sub>-Z<sub>6</sub> Z<sub>7</sub> Z<sub>8</sub> Z<sub>9</sub>

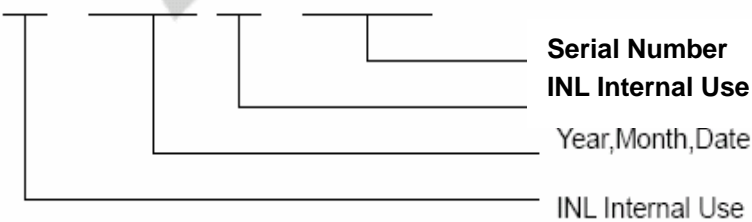

### 9. Packing Form

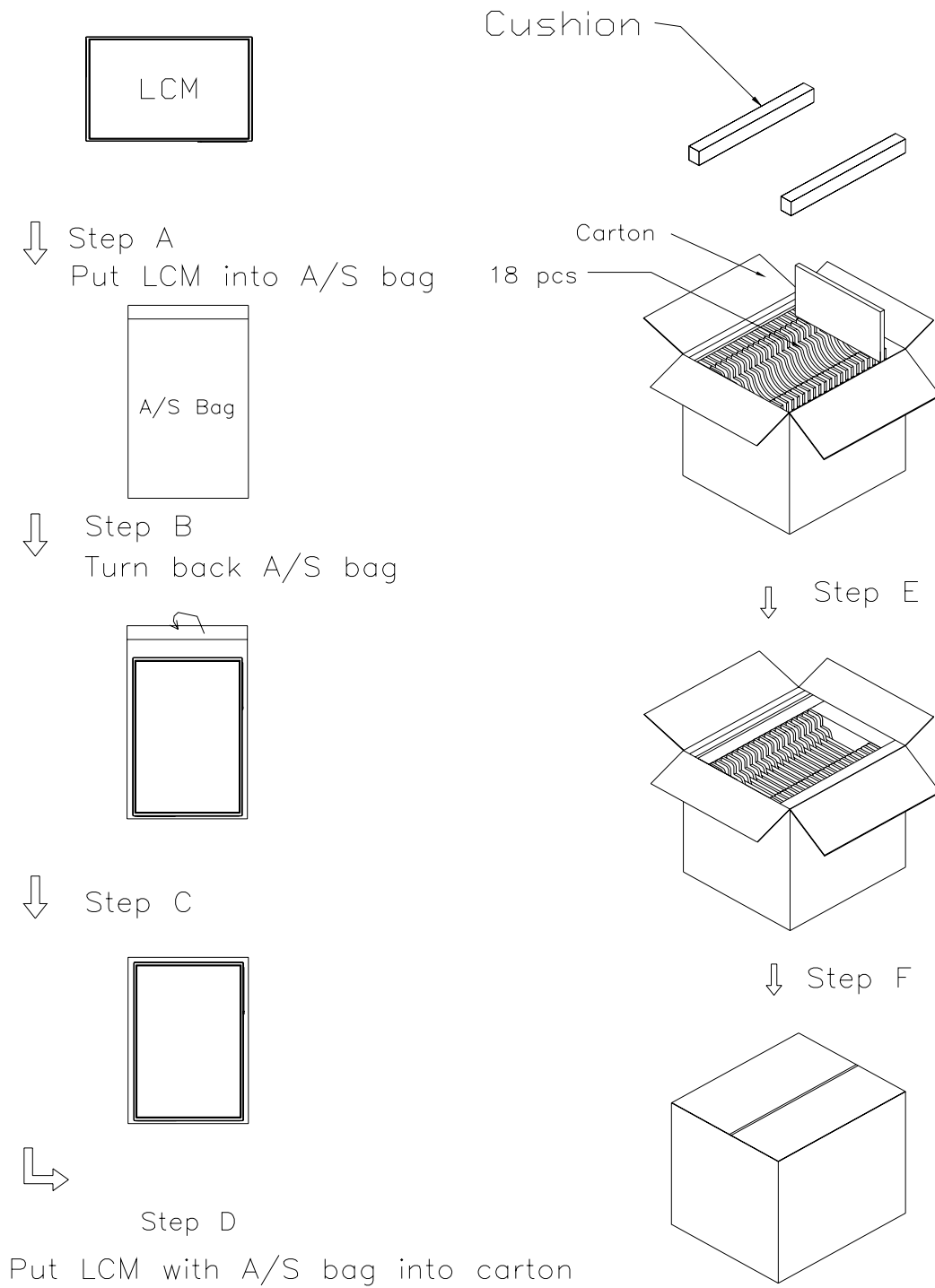

### 10. Mechanical Drawings 10-1 Front side

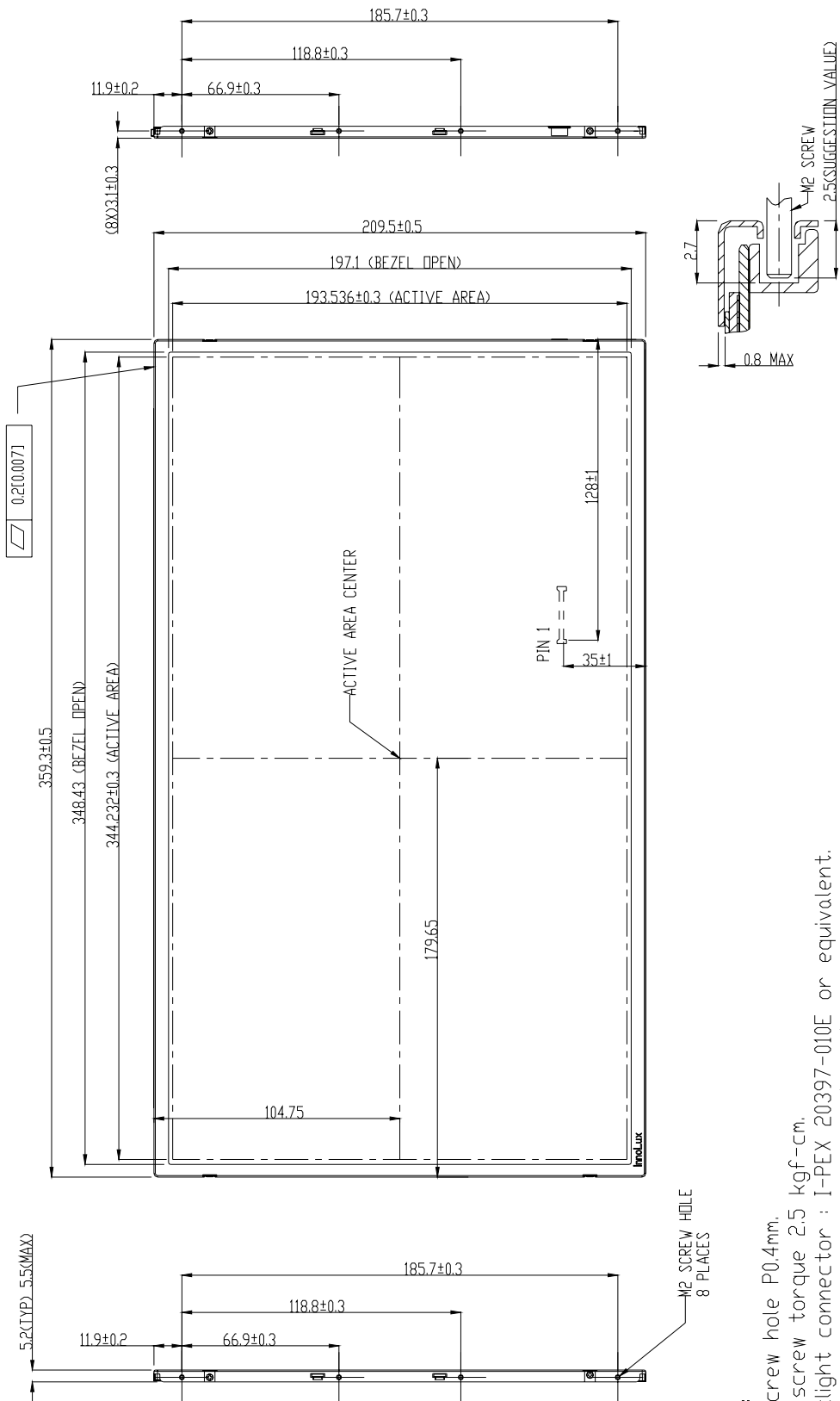

- NOTES:
- 1.M2 screw hole P0.4mm.
  - 2.Max screw torque 2.5 kgf-cm.
  - 3.Backlight connector : I-PEX 20397-010E or equivalent.
  - 4.LCD input connector : I-PEX 20455-040E-0\* or equivalent.
  - 5.In order to avoid IC damage, it is not allowed to have such overlappings as cables or antennas, camera, WLAN, WWAN over these COF locations.



### 10-2 Rear side

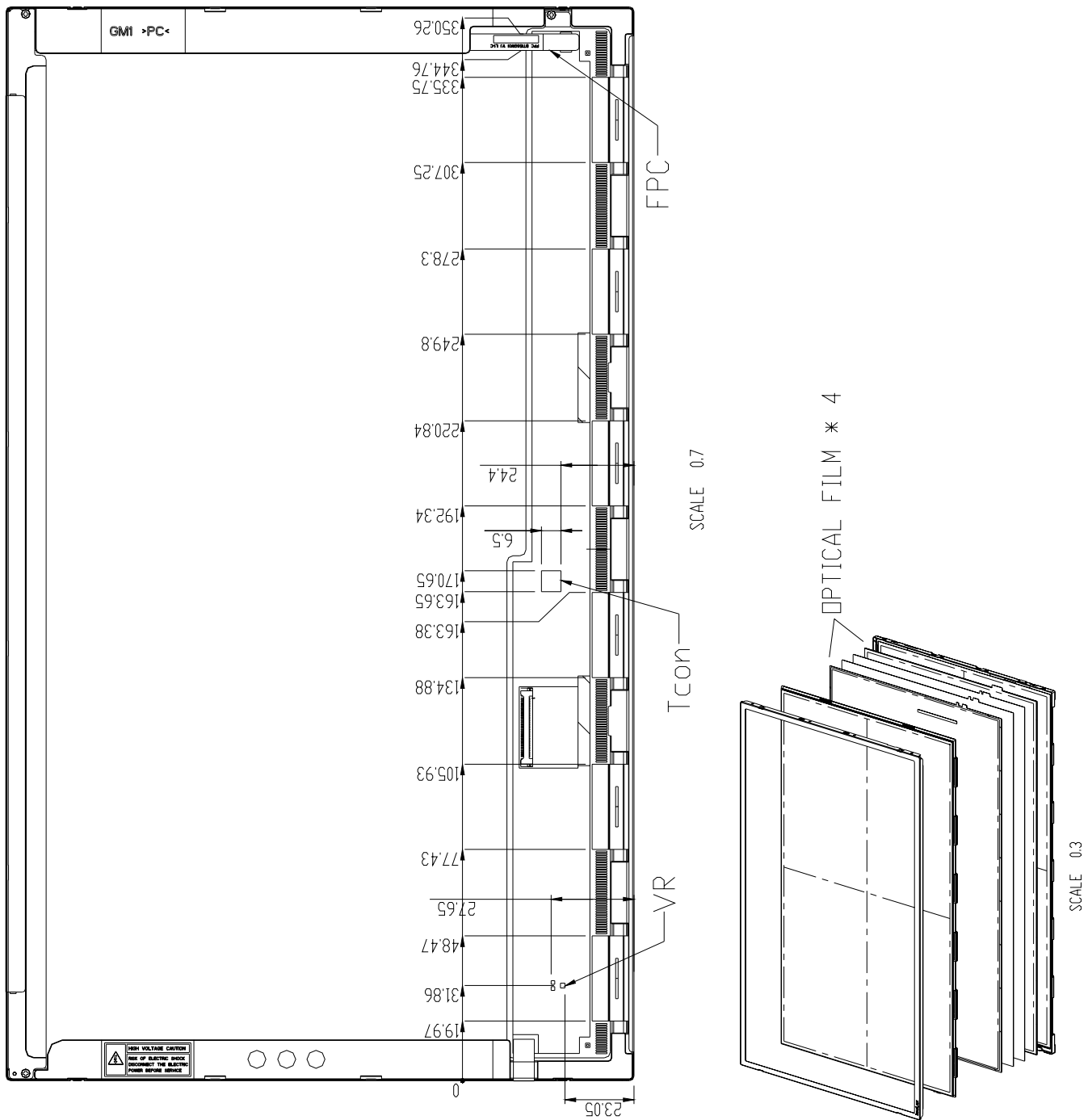

## 11. System Cover Design Notice

### 11-1. Interference examination (TCON / VR / COF IC vs cable or wire)

Definition :

- a) Cable or wire overlap with TCON 、 VR 、 COF IC is forbidden for preventing from abnormal display after backpack test, hinge test, twist test or pogo test.
- b) Cable or wire bypass TCON 、 VR 、 COF IC is recommended.

### 11-2. System inner surface examination

Definition :

- a) Sponge tape or poron stick on PCBA or frame is forbidden for preventing from abnormal display after backpack test, hinge test, twist test or pogo test.

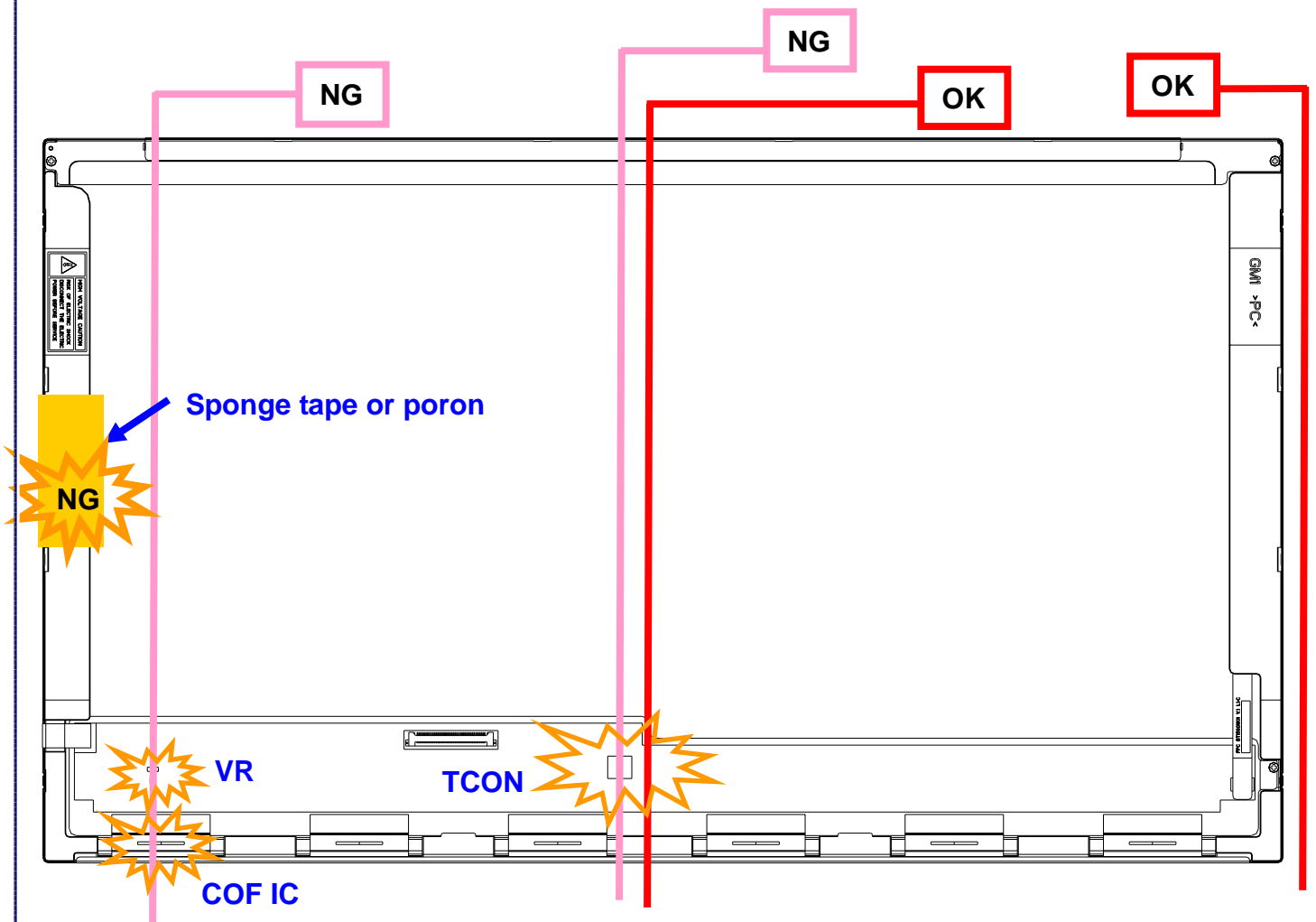

**Appendix: EDID Code**

	Byte (hex)	Field Name and Comments	Value (hex)	Value (binary)
Header	0	Header	00	00000000
	1	Header	FF	11111111
	2	Header	FF	11111111
	3	Header	FF	11111111
	4	Header	FF	11111111
	5	Header	FF	11111111
	6	Header	FF	11111111
	7	Header	00	00000000
Vendor / Product EDID Version	8	EISA manufacture code = 3 Character ID	25	00100101
	9	EISA manufacture code (Compressed ASCII)	CC	11001100
	0A	Panel Supplier Reserved – Product Code	05	00000101
	0B	Panel Supplier Reserved – Product Code	00	00000000
	0C	LCD module Serial No - Preferred but Optional (“0” if not used)	00	00000000
	0D	LCD module Serial No - Preferred but Optional (“0” if not used)	00	00000000
	0E	LCD module Serial No - Preferred but Optional (“0” if not used)	00	00000000
	0F	LCD module Serial No - Preferred but Optional (“0” if not used)	00	00000000
	10	Week of manufacture-->--	00	00000000
	11	Year of manufacture – 1990 (ex. 2005-1990=15) --> <b>2009</b>	13	00010011
	12	EDID structure version # = 1	01	00000001
	13	EDID revision # = 3	03	00000011
Display Parameters	14	Video I/P definition = Digital I/P (80h)	80	10000000
	15	Max H image size = (34.423=34 cm)	22	00100010
	16	Max V image size = (19.354=19 cm)	13	00010011
	17	Display gamma = (gamma ×100)-100 = Example: ( 2.2×100 ) – 100 = 120	78	01111000
	18	Feature support ( no DPMS, Active off, RGB, timing BLK 1)	0A	00001010
Panel Color Coordinates	19	Red/Green Low bit (RxRy/GxGy)	C8	11001000
	1A	Blue/White Low bit (BxBY/WxWy)	85	10000101
	1B	Red x Rx=0.620	9E	10011110
	1C	Red y Ry=0.340	57	01010111
	1D	Green x Gx=0.330	54	01010100
	1E	Green y Gy=0.605	9B	10011011
	1F	Blue x Bx=0.150	26	00100110
	20	Blue y By=0.070	12	00010010
	21	White X Wx=0.313	50	01010000
	22	White Y Wy=0.329	54	01010100
Established Timings	23	Established timings 1 (00h if not used)	00	00000000
	24	Established timings 2 (00h if not used)	00	00000000
	25	Manufacturer’s timings (00h if not used)	00	00000000

Standard Timing ID	26	Standard timing ID1 (01h if not used)	01	00000001
	27	Standard timing ID1 (01h if not used)	01	00000001
	28	Standard timing ID2 (01h if not used)	01	00000001
	29	Standard timing ID2 (01h if not used)	01	00000001
	2A	Standard timing ID3 (01h if not used)	01	00000001
	2B	Standard timing ID3 (01h if not used)	01	00000001
	2C	Standard timing ID4 (01h if not used)	01	00000001
	2D	Standard timing ID4 (01h if not used)	01	00000001
	2E	Standard timing ID5 (01h if not used)	01	00000001
	2F	Standard timing ID5 (01h if not used)	01	00000001
	30	Standard timing ID6 (01h if not used)	01	00000001
	31	Standard timing ID6 (01h if not used)	01	00000001
	32	Standard timing ID7 (01h if not used)	01	00000001
	33	Standard timing ID7 (01h if not used)	01	00000001
	34	Standard timing ID8 (01h if not used)	01	00000001
35	Standard timing ID8 (01h if not used)	01	00000001	
Timing Descriptor #1	36	Pixel Clock/10,000 (Pixel Clock=71.1MHz) (LSB)	<b>C6</b>	11000110
	37	Pixel Clock/10,000 (Pixel Clock=71.1MHz) (MSB)	<b>1B</b>	00011011
	38	Horizontal Active = 1366 pixels (lower 8 bits)	56	01010110
	39	Horizontal Blanking (Thbp) = 127 pixels (lower 8 bits)	<b>7F</b>	01111111
	3A	Horizontal Active/Horizontal blanking (Thbp) (upper4:4 bits)	50	01010000
	3B	Vertical Active = 768 lines	00	00000000
	3C	Vertical Blanking (Tvbp) = 25 lines (DE Blanking typ. for DE only panels)	<b>19</b>	00011001
	3D	Vertical Active : Vertical Blanking (Tvbp) (upper4:4 bits)	30	00110000
	3E	Horizontal Sync, Offset (Thfp) = 31 pixels	<b>1F</b>	00011111
	3F	Horizontal Sync, Pulse Width = 21 pixels	<b>15</b>	00010101
	40	Vertical Sync, Offset (Tvfp) = 3 lines Sync Width = 4 lines	<b>34</b>	00110100
	41	Horizontal Vertical Sync Offset/Width upper 2 bits	00	00000000
	42	Horizontal Image Size =344 mm	58	01011000
	43	Vertical image Size = 194 mm	C2	11000010
	44	Horizontal Image Size / Vertical image size	10	00010000
45	Horizontal Border = 0 (Zero for Notebook LCD)	00	00000000	
46	Vertical Border = 0 (Zero for Notebook LCD)	00	00000000	
47	Signal (non-intr, norm, no stero, sep sync, neq pol)	18	00011000	
Timing Descriptor #2	48	Detailed timing/monitor	00	00000000
	49	descriptor #2	00	00000000
	4A		00	00000000
	4B		00	00000000
	4C		00	00000000
	4D		00	00000000
4E		00	00000000	

	4F		00	00000000
	50		00	00000000
	51		00	00000000
	52		00	00000000
	53		00	00000000
	54		00	00000000
	55		00	00000000
	56		00	00000000
	57		00	00000000
	58		00	00000000
	59		00	00000000
Timing Descriptor #3 Dell specific information	5A	Detailed timing/monitor	00	00000000
	5B	descriptor #3	00	00000000
	5C		00	00000000
	5D		FE	11111110
	5E		00	00000000
	5F	Vender P/N 1 <sup>st</sup> Character "I"	49	01001001
	60	Vender P/N 2 <sup>nd</sup> Character "N"	4E	01001110
	61	Vender P/N 3 <sup>rd</sup> Character "L"	4C	01001100
	62		0A	00001010
	63		20	00100000
	64		20	00100000
	65		20	00100000
	66		20	00100000
	67		20	00100000
	68		20	00100000
	69		20	00100000
	6A		20	00100000
6B		20	00100000	
Timing Descriptor #4	6C	Detailed timing/monitor	00	00000000
	6D	descriptor #4	00	00000000
	6E		00	00000000
	6F		00	00000000
	70		00	00000000
	71	Manufacture P/N "B"	42	01000010
	72	Manufacture P/N "T"	54	01010100
	73	Manufacture P/N "1"	31	00110001
	74	Manufacture P/N "5"	35	00110101
	75	Manufacture P/N "6"	36	00110110
	76	Manufacture P/N "G"	47	01000111
	77	Manufacture P/N "W"	57	01010111
78	Manufacture P/N "0"	30	00110000	

SPEC NO. BT156GW01 V.2

PAGE 28/ 28

	79	Manufacture P/N "1"	31	00110001
	7A	Manufacture P/N "V"	56	01010110
	7B	Manufacture P/N "2"	32	00110010
	7C		32	00110010
	7D		10	00010000
Checksum	7E	Extension flag	00	00000000
	7F	Checksum	<b>A6</b>	10100110